

# COMPANION FLANGE CONNECTION

230 AND LARGER SPIRAL DUCTWORK/FITTINGS

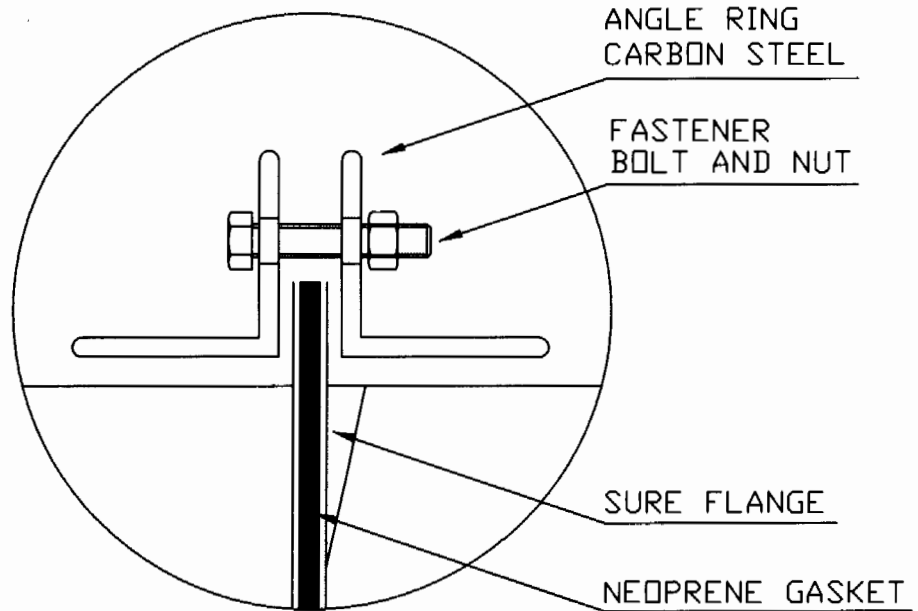
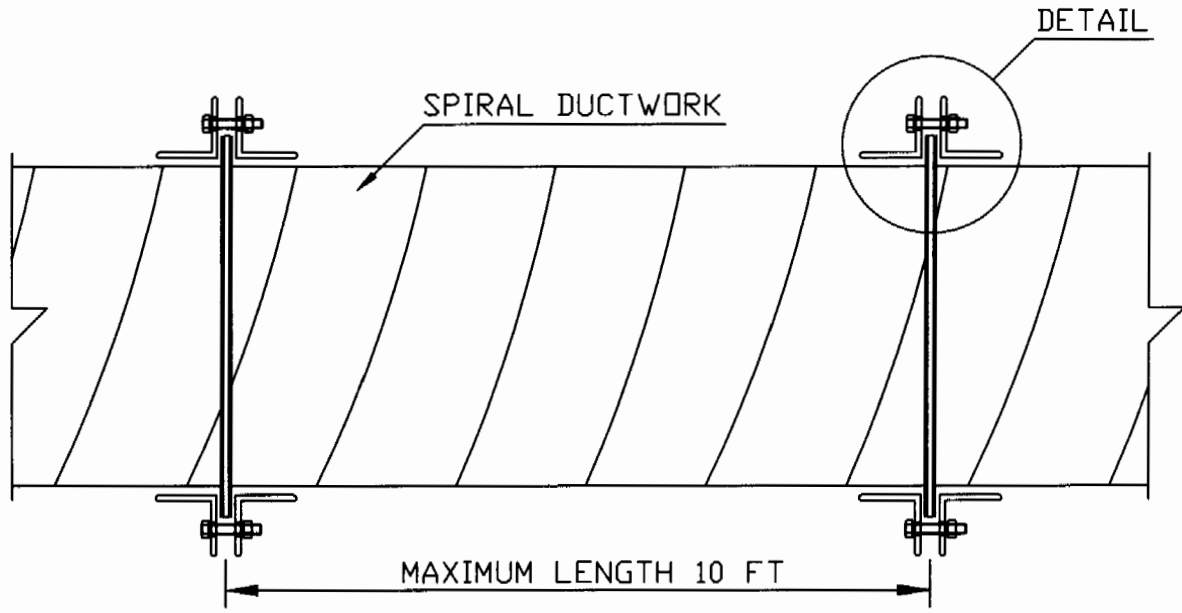

COMPANION FLANGE  
DETAIL

## DRAWING NOTES

1. REFER TO SMACNA THIRD EDITION 2005, DUCT CONSTRUCTION STANDARDS FOR THE FOLLOWING.
  - A. MANUFACTURING STANDARDS FOR SPIRAL DUCTWORK AND FITTINGS.
  - B. METAL GAUGES FOR SPIRAL DUCTWORK AND FITTINGS.
  - C. REINFORCEMENTS, TYPE, SIZE, AMOUNT AND FASTENING METHOD.
  - D. COMPANION ANGLE, SIZE, AND FASTENING METHOD.